



Model Number

UB4000-30GM-H3-V1

Single head system

Features

- Separate evaluation
- Direct detection mode

Diagrams

Characteristic response curves

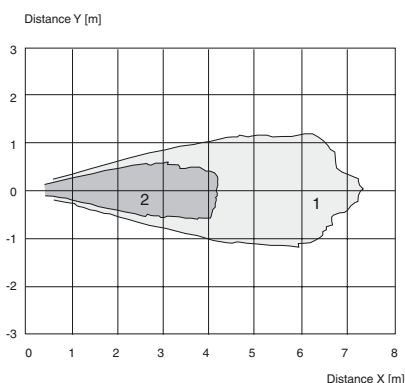

Curve 1: flat surface 100 mm x 100 mm
Curve 2: round bar, Ø 25 mm

Technical data

General specifications

Sensing range	200 ... 4000 mm
Adjustment range	240 ... 4000 mm
Dead band	0 ... 200 mm ¹⁾
Standard target plate	100 mm x 100 mm
Transducer frequency	approx. 85 kHz

Electrical specifications

Operating voltage U_B	10 ... 30 V DC, ripple 10 % _{SS}
No-load supply current I_0	≤ 30 mA

Input

Input type	1 pulse input for transmitter pulse (clock) 0-level (active): < 5 V ($U_B > 15 V$) 1-level (inactive): > 10 V ... $+U_B$ ($U_B > 15 V$) 0-level (active): < 1/3 U_B ($10 V < U_B < 15 V$) 1-level (inactive): > 2/3 U_B ... $+U_B$ ($10 V < U_B < 15 V$)
Pulse length	40 ... 600 μs (typ. 500 μs) ²⁾
Pause length	≥ 50 x pulse length
Impedance	10 kOhm internal connected to $+U_B$

Output

Output type	1 pulse output for echo run time, short-circuit proof open collector PNP with pulldown resistor = 22 kOhm level 0 (no echo): $-U_B$ level 1 (echo detected): ≥ $(+U_B - 2 V)$
Rated operating current I_e	15 mA, short-circuit/overload protected
Temperature influence	the echo propagation time: 0.17 % / K

Ambient conditions

Ambient temperature	-25 ... 85 °C (-13 ... 185 °F)
Storage temperature	-40 ... 85 °C (-40 ... 185 °F)

Mechanical specifications

Connection type	Connector M12 x 1, 4-pin
Degree of protection	IP67
Material	
Housing	nickel plated brass; plastic components: PBT
Transducer	epoxy resin/hollow glass sphere mixture; polyurethane foam
Mass	180 g

Compliance with standards and directives

Standard conformity	
Standards	EN 60947-5-2:2007+A1:2012 IEC 60947-5-2:2007 + A1:2012

Approvals and certificates

UL approval	cULus Listed, General Purpose
CSA approval	cCSAus Listed, General Purpose
CCC approval	CCC approval / marking not required for products rated ≤ 36 V

Dimensions

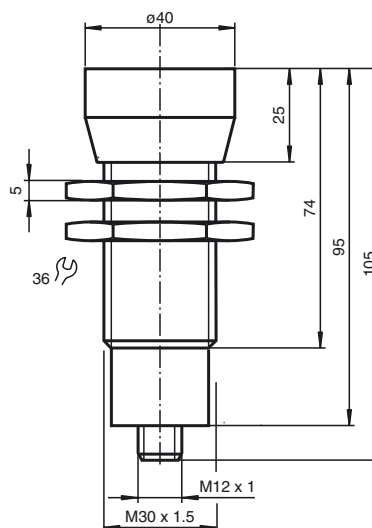

Electrical Connection

Standard symbol/Connection:

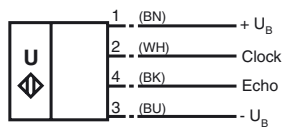

2 = Emitter pulse input
 4 = Echo propagation time output
 Core colours in accordance with EN 60947-5-2.

Pinout

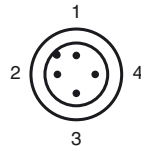

Wire colors in accordance with EN 60947-5-2

1	BN	(brown)
2	WH	(white)
3	BU	(blue)
4	BK	(black)

Accessories

BF 30
 Mounting flange, 30 mm

BF 5-30
 Universal mounting bracket for cylindrical sensors with a diameter of 5 ... 30 mm

V1-G-2M-PVC
 Female cordset, M12, 4-pin, PVC cable

Function

The sensing range is determined in the downstream evaluation electronics such as PLC modules or other existing evaluation units.

The object distance in pulse-echo mode is obtained from the echo time Δt . The emission of an ultrasonic pulse starts simultaneously with the falling slope of the clock input signal.

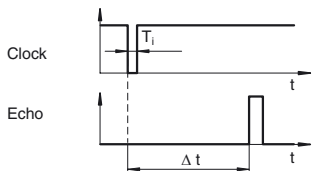

We recommend the usage of a npn-transistor to trigger the sensors clock input. The sensors clock input is connected to the $+U_B$ potential internally by means of a pull up resistor.

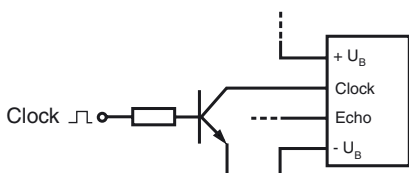

- 1) The unusable area (blind range) BR depends on the pulse duration T_i .
The unusable area reaches a minimum with the shortest pulse duration.
- 2) The sensors detection range depends on the pulse duration T_i .
With pulse duration $<$ typical pulse duration, the sensors detection range may be reduced.